

TRAINER OVERVIEW TABLE OF CONTENTS

PAGE	TITLE
1	OVERVIEW
2	BAS AND ICP WIRING
3	RA5000 - COMPACTLOGIX
4	MICRO850
5	MICRO820
6	LMC - LINEAR ACTUATOR

PART NUMBER EXPLANATION

TRN-XXX-YYY-ZZZ

ADDITIONAL OPTIONS INCLUDING:
 AID - ANALOG INPUTS AND OUTPUTS
 HMI - TOUCH SCREEN
 LMC - LINEAR ACTUATOR
 CUS - CUSTOM CONFIGURATION

PLC STANDARD OPTIONS ARE:
 RA5000 - COMPACTLOGIX
 MICRO850
 MICRO820
 CUS - CUSTOM CONFIGURATION

CONFIGURATION. STANDARD OPTIONS ARE:
 BAS - BASIC TRAINER BUTTONS AND LIGHTS
 ICP - ADDITION OF DRIVE, MOTOR, ANALOG,
 AND ETHERNET SWITCH
 CUS - CUSTOM CONFIGURATION

THIS DRAWING IS THE PROPERTY OF TWCONTROLS LLC AND IS LOANED ON THE EXPRESS CONDITION THAT IT IS NOT TO BE USED IN ANY WAY DELETTERIOUS TO THE INTERESTS OF THE TW CONTROLS LLC. THE ACCEPTANCE OF THIS DRAWING WILL BE CONSIDERED AS AN ADMISSION OF THE EXCLUSIVE OWNERSHIP IN AND TO THE DRAWING BY THE TW CONTROLS LLC.

TW CONTROLS LLC
 PO BOX 21252 ROANOKE, VA 24018
 540-785-2770

GETTING STARTED GUIDE



PLC TRAINERS
 GENERAL NOTES

DRAWN: TIM WILBORNE
 CHECKED: AW
 REVISION: 3.04

DATE: 07/24/2023
 APPROVED: TW
 none SCALE: NONE

ALL TRAINERS

1/6

UNDERSTANDING WIRING DIAGRAMS

01 ← THIS IS A RUNG NUMBER.

02 WIRE NUMBER EXAMPLE. THIS WIRE WOULD BE 1021 WHERE:
 X=PAGE NUMBER
 YY=RUNG NUMBER
 N=INCREMENTAL NUMBER OF DEVICE FROM LEFT TO RIGHT

03

04

05

06

07

08

09

10

11

12

13

14

15

16

17

REFERENCES TO CONNECTIONS ON OTHER SHEETS

WIRE NUMBER REF WIRE NUMBER REF WIRE NUMBER REF WIRE NUMBER REF

WIRE COLOR CODES

BLACK	120 VAC
WHITE	NEUTRAL
GREEN	GROUND
BLUE SOLID	+24VDC
WHITE WITH STRIPE	0VDC

WIRE SIZE, TYPE, AND TORQUE

WIRE SIZE, TYPE, AND TORQUE	
PUSH B	
PUSH BUTTONS SWITCHES LIGHTS	COPPER WIRE 75C ONLY 20-4 AWG 9 LB-IN
POWERFLEX 525	
POWER WIRE	COPPER WIRE 75C ONLY 18-10 AWG 17 LB-IN
CONTROL WIRE	COPPER WIRE 75C ONLY 26-16 AWG 7 LB-IN

Diagram showing a normally open contact (NO) and a normally closed contact (NC) connected to a relay or contactor coil. The wire number is 105CR1. The relay or contactor coil is labeled NC105 CONTACT REF and NC106 CONTACT REF.

120VAC 1 PHASE - FACTORY WIRING

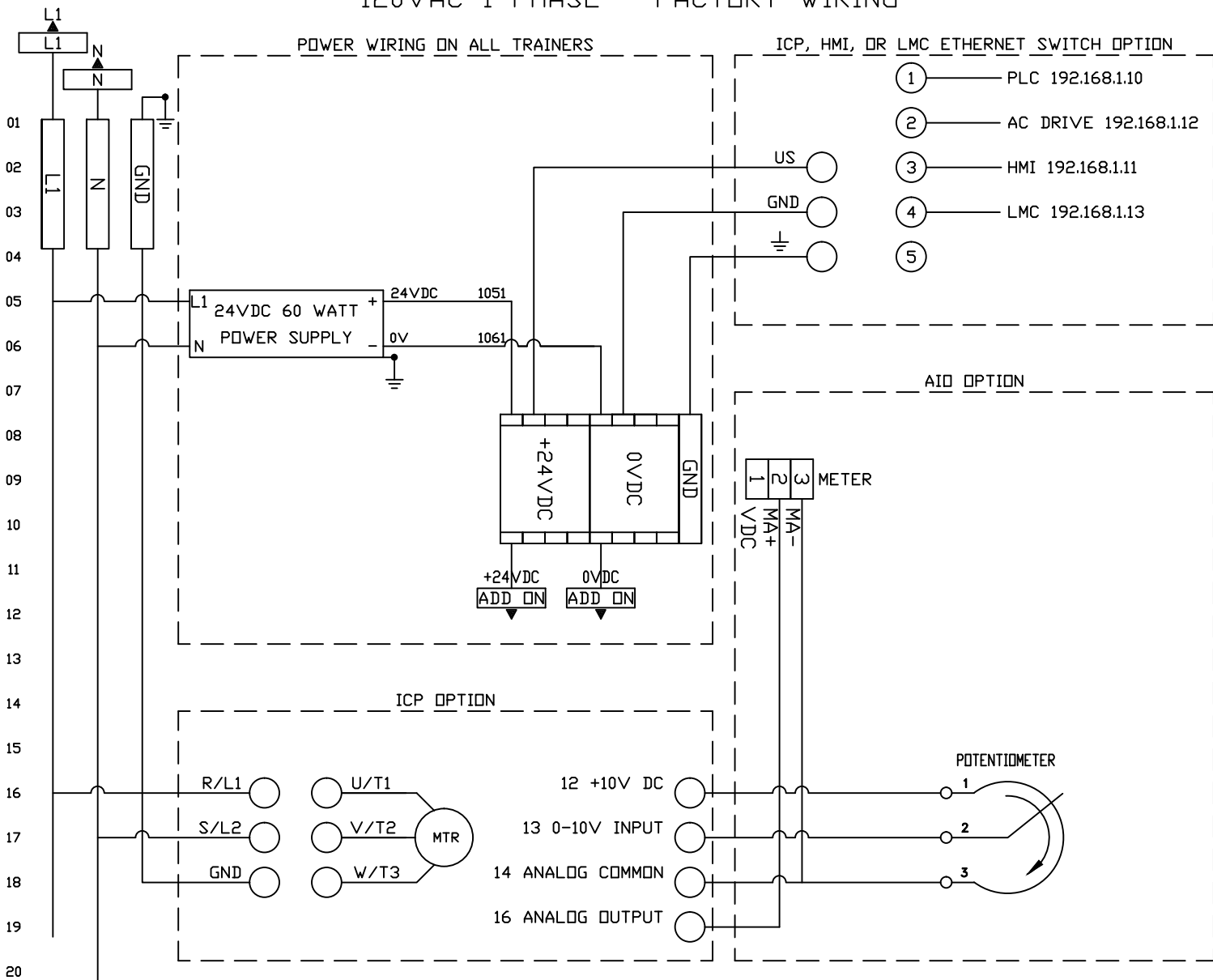

TWCONTROLS.COM

TW CONTROLS LLC
 PO BOX 21252 ROANOKE, VA 24018
 540-785-2770

THIS DRAWING IS THE PROPERTY OF TWCONTROLS LLC AND IS LOANED ON THE EXPRESS CONDITION THAT IT IS NOT TO BE USED IN ANY WAY DELETTERIOUS TO THE INTERESTS OF THE TW CONTROLS LLC. THE ACCEPTANCE OF THIS DRAWING WILL BE CONSIDERED AS AN ADMISSION OF THE EXCLUSIVE OWNERSHIP IN AND TO THE DRAWING BY THE TW CONTROLS LLC.

PLC TRAINERS
 TRN-BAS AND TRN-ICP
 POWER WIRING

DRAWN: TIM WILBORNE
 CHECKED: AW
 REVISION: 3.04
 DATE: 07/24/2023
 APPROVED: TW

ALL TRAINERS 2/6

none SCALE: NONE

24VDC USER INSTALLED WIRING

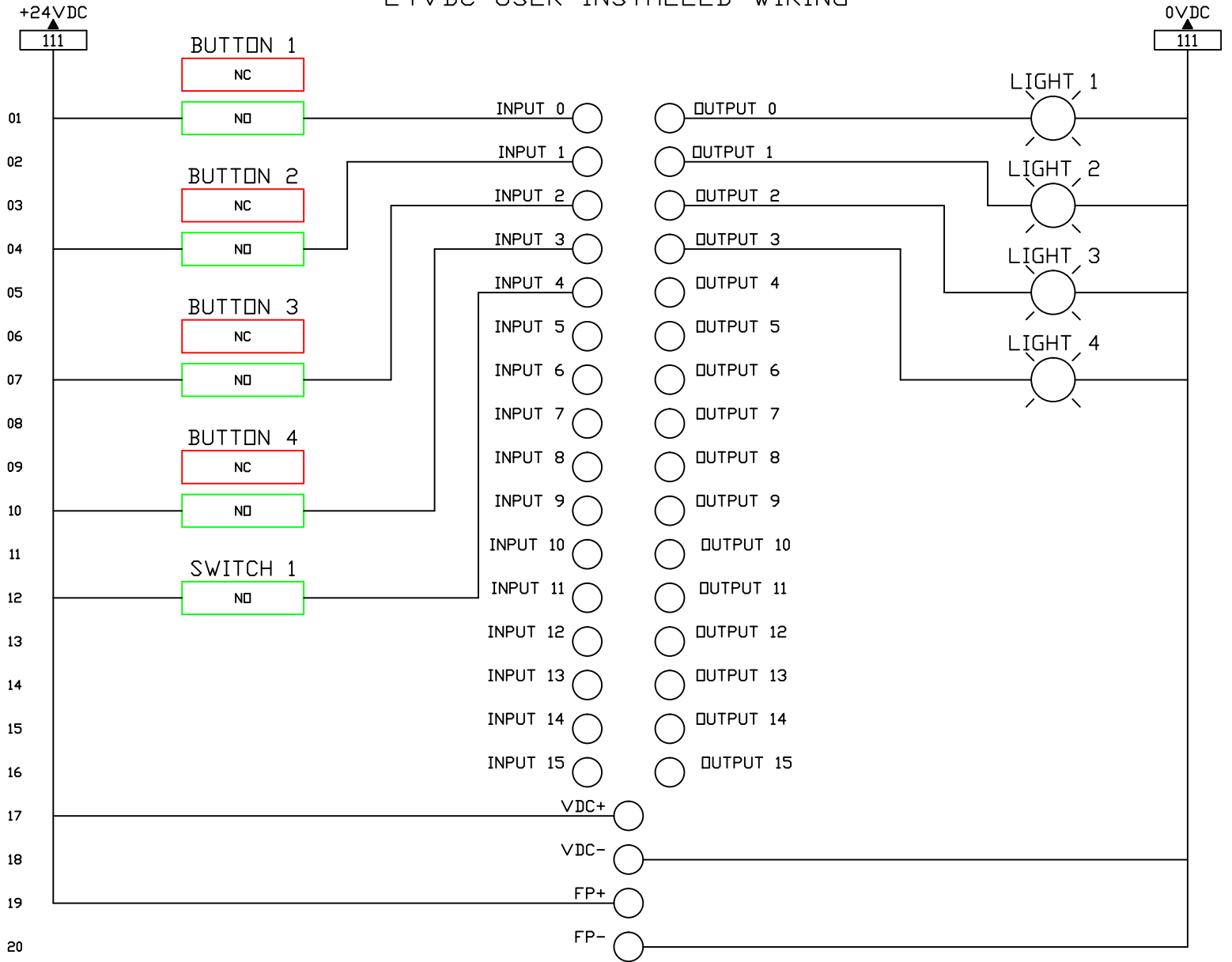

TMCCONTROLS.COM

TW CONTROLS LLC
 PO BOX 21252 ROANOKE, VA 24018
 540-785-2770

THIS DRAWING IS THE PROPERTY OF TMCCONTROLS LLC
 AND IS LOANED ON THE EXPRESS
 CONDITION THAT IT IS NOT TO BE USED IN ANY WAY DELETERIOUS
 TO THE INTERESTS OF THE TW CONTROLS LLC.
 THE ACCEPTANCE OF THIS DRAWING WILL BE CONSIDERED AS
 AN ADMISSION OF THE EXCLUSIVE OWNERSHIP IN AND TO THE
 DRAWING BY THE TW CONTROLS LLC.

PLC TRAINERS
COMPACTLOGIX GETTING STARTED
PLC WIRING

DRAWN: TIM WILBORNE	DATE: 07/24/2023
CHECKED: AW	APPROVED: TW
REVISION: 3.04	none
SCALE: NONE	

RA5000

3/6

24VDC USER INSTALLED WIRING

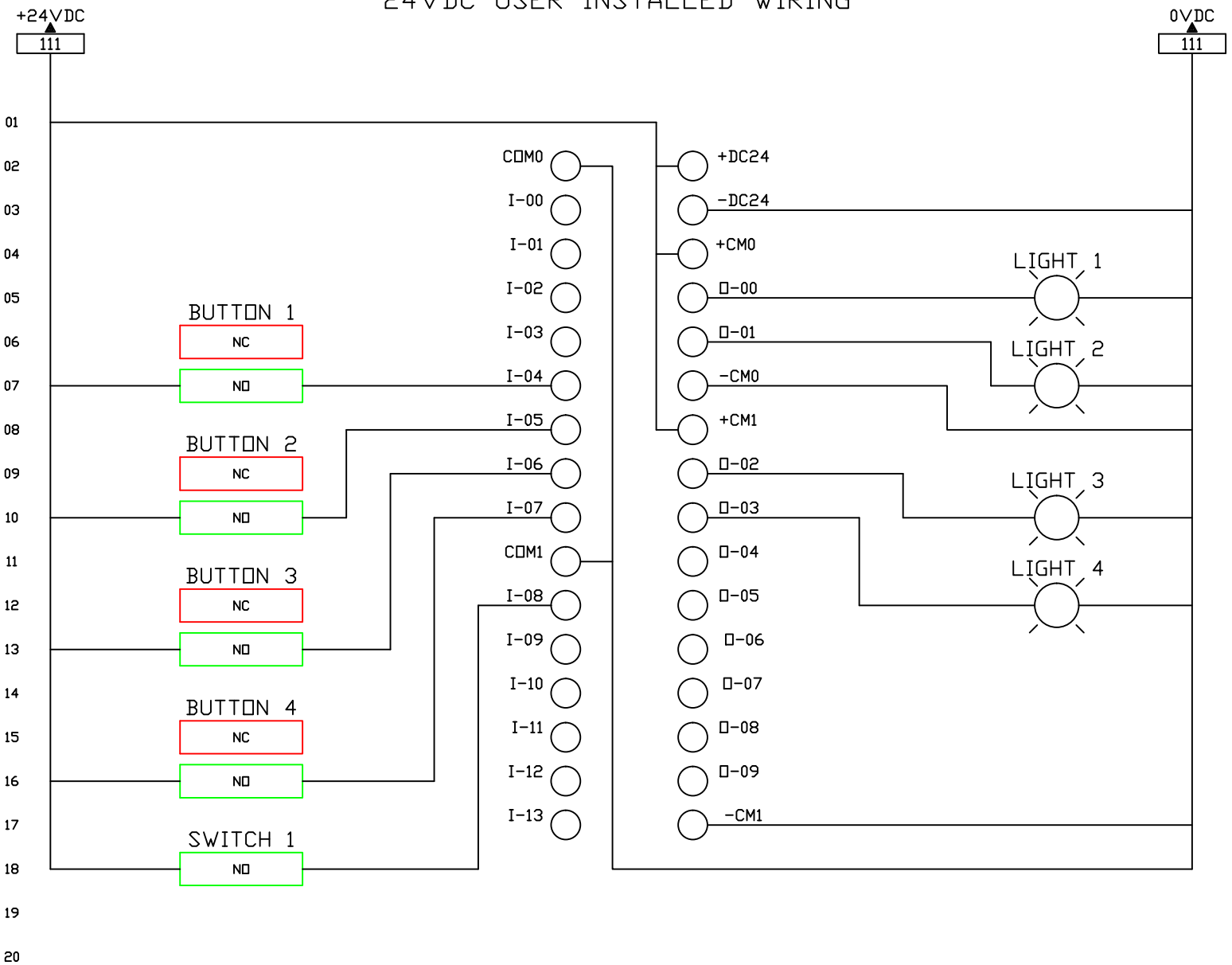

TWCONTROLS.COM

TW CONTROLS LLC
 PO BOX 21252 ROANOKE, VA 24018
 540-785-2770

THIS DRAWING IS THE PROPERTY OF TWCONTROLS LLC
 AND IS LOANED ON THE EXPRESS
 CONDITION THAT IT IS NOT TO BE USED IN ANY WAY DELETTERIOUS
 TO THE INTERESTS OF THE TW CONTROLS LLC.
 THE ACCEPTANCE OF THIS DRAWING WILL BE CONSIDERED AS
 AN ADMISSION OF THE EXCLUSIVE OWNERSHIP IN AND TO THE
 DRAWING BY THE TW CONTROLS LLC.

PLC TRAINERS
MICRO 850 GETTING STARTED
PLC WIRING

DRAWN: TWM WILBORNE	DATE: 07/24/2023
CHECKED: AW	APPROVED: TW
REVISION: 3.04	SCALE: NONE

MICRO850

4/6

24VDC USER INSTALLED WIRING

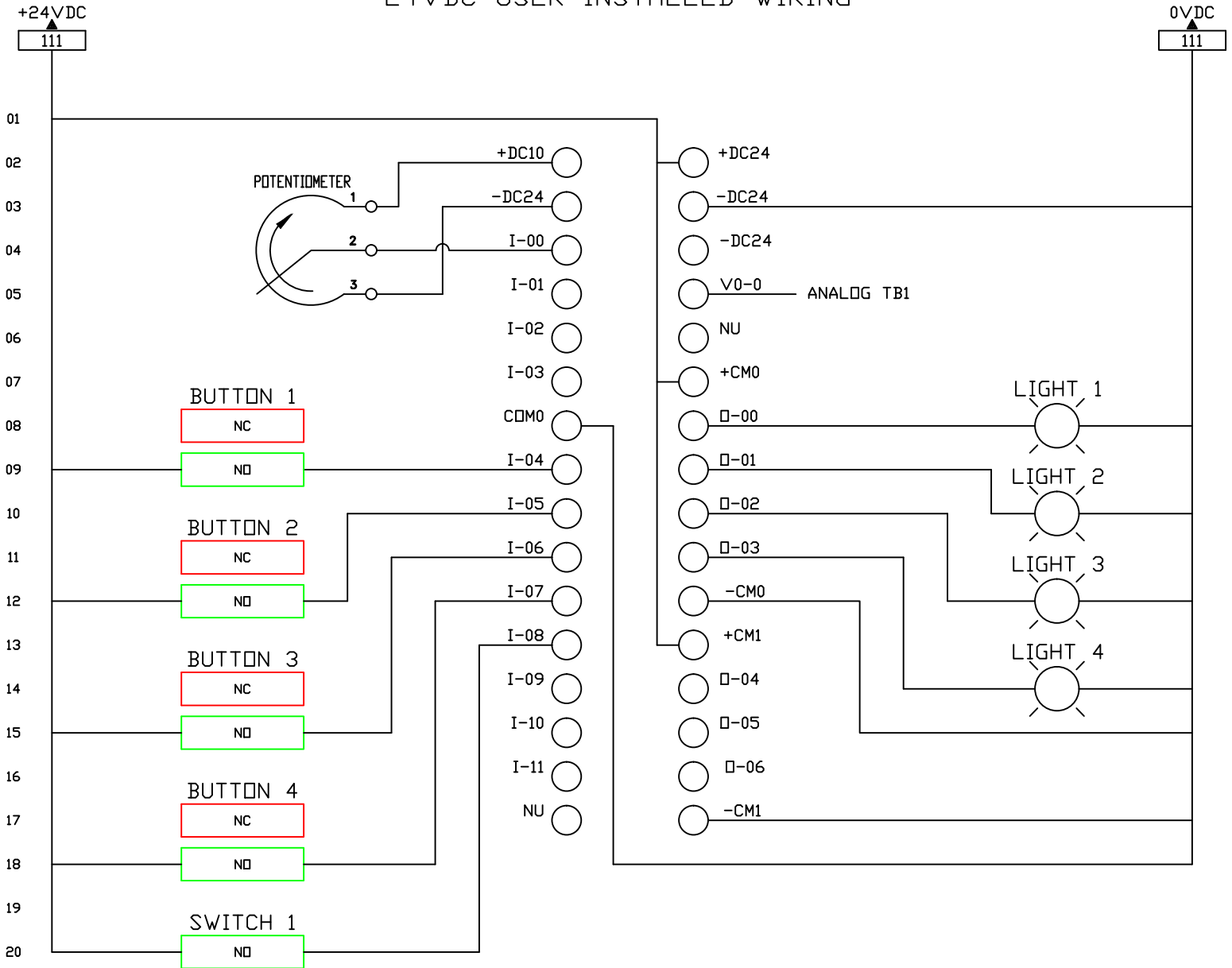

TMCNTRLS.COM

TW
CONTROLS LLC
 PO BOX 21252 ROANOKE, VA 24018
 540-788-2770

THIS DRAWING IS THE PROPERTY OF TMCNTRLS LLC
 AND IS LOANED ON THE EXPRESS
 CONDITION THAT IT IS NOT TO BE USED IN ANY WAY DELETERIOUS
 TO THE INTERESTS OF THE TW CONTROLS LLC.
 THE ACCEPTANCE OF THIS DRAWING WILL BE CONSTRUED AS
 AN ADMISSION OF THE EXCLUSIVE OWNERSHIP IN AND TO THE
 DRAWING BY THE TW CONTROLS LLC.

PLC TRAINERS
MICRO 820 GETTING STARTED
PLC WIRING

DRAWN: TIM WILBORNE	DATE: 07/24/2023
CHECKED: AW	APPROVED: TW
REVISION: 3.04	SCALE: NONE

MICRO820

5/6

24VDC FACTORY INSTALLED WIRING

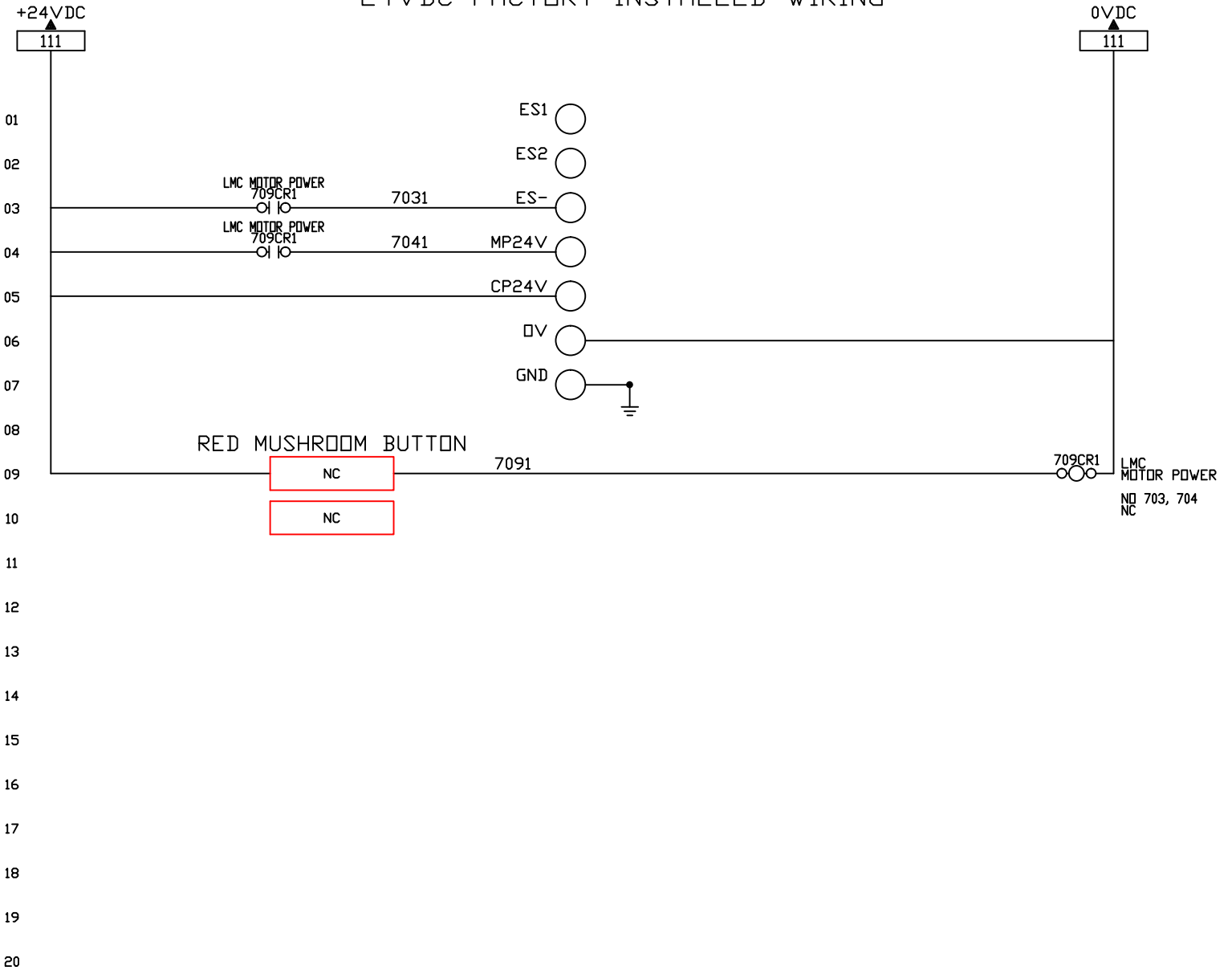

TWCONTROLS.COM

TW CONTROLS LLC
 PO BOX 21252 ROANOKE, VA 24018
 540-785-2770

THIS DRAWING IS THE PROPERTY OF TWCONTROLS LLC
 AND IS LOANED ON THE EXPRESS
 CONDITION THAT IT IS NOT TO BE USED IN ANY WAY DELETERIOUS
 TO THE INTERESTS OF THE TW CONTROLS LLC.
 THE ACCEPTANCE OF THIS DRAWING WILL BE CONSIDERED AS
 AN ADMISSION OF THE EXCLUSIVE OWNERSHIP IN AND TO THE
 DRAWING BY THE TW CONTROLS LLC.

PLC TRAINERS
 LINEAR ACTUATOR

DRAWN: TIM WILBORNE
 CHECKED: AW
 REVISION: 3.04
 DATE: 07/24/2023
 APPROVED: TW
 none SCALE: NONE

LMC

6/6